

# Professional Sealed Side Burner Specs

## Gas Requirements:

NATURAL

- 1/2" NPT male with 3/8" flare adapter
- Operating Pressure: 4" W.C.
- Supply Pressure: 5" to 14" W.C.

propane

- 1/2" NPT male with 3/8" flare adapter
- Operating Pressure: 10" W.C.
- Supply Pressure: 11" to 14" W.C.

## Side Burner Dimensions (Built-in)

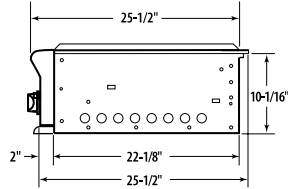
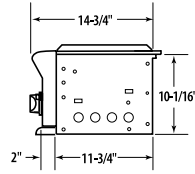

## Side Burner Dimensions (30" Cart Mount)

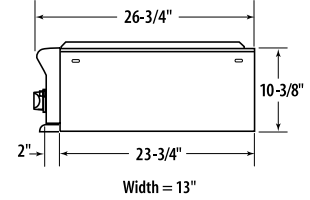
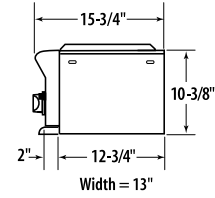

## Professional Side Burner Island Preparation for Non-Combustible Enclosure

MODEL	A
BGB131-BI	12"
BGB132-BI	22-3/8"

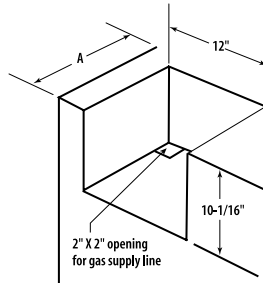

## Professional Side Burner Island Preparation for Combustible Enclosure

MODEL	A
BGB131	13-7/8"
BGB132	24-7/8"

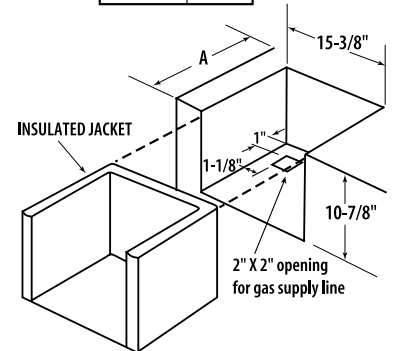

NOTE: The BGB built-in models must be installed in non-combustible material only

NOTE: For installation in combustible material must use BGB131 or BGB132 with Insulation Jacket

MODEL NUMBER	BGB131	BGB131-BI	BGB132	BGB132-BI
30" CART MOUNT	•		•	
BUILT-IN		•		•
SIDE BURNER(S)	1@17,000 Btu/hr	1@17,000 Btu/hr	2@17,000 Btu/hr	2@17,000 Btu/hr

Ordering Data: Please specify gas type (natural or propane) when ordering.



Because of continuing product improvement these specifications are subject to change without notice.



For more information on our complete line of residential kitchen appliances or to find out more about our outdoor product line, please call 1.800.433.8466 or visit [www.dcsappliances.com](http://www.dcsappliances.com)

©2004 DCS 5800 Skylab Road, Huntington Beach, CA 92647